

USBula EB – Serial to USB-Flash-Drive evaluation board

Datasheet

USBula EB is an evaluation board for USBula, the ready-to-use firmware accessing USB flash drives from your application over a simple serial protocol.

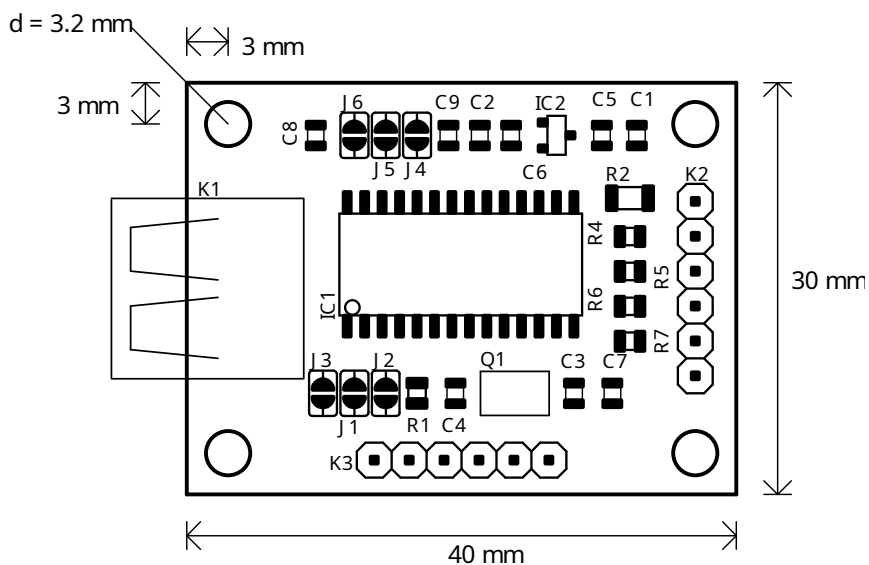
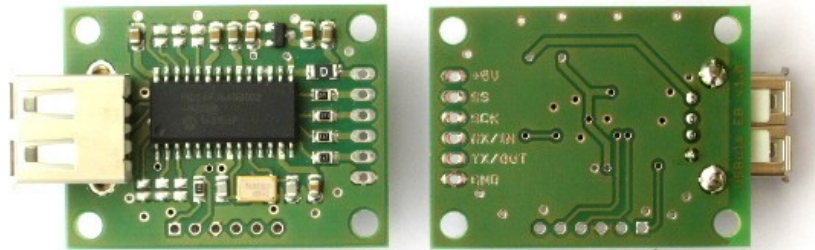

Main features

- Connects USB memory stick to your application without USB programming
- Single +5V supply voltage (+3,3V regulator onboard)
- +5V tolerant serial interface with simple protocol for file access

Connection

USBula EB has a standard USB-A connector (K1) for the USB-Flash-Drive. The supply voltage and serial interface is routed to a 2,54mm pin header (K2).

Header K2		Description
1	+5V	Power supply voltage +5V Current depends on the used USB flash drive (~100 mA).
2	SS	Reserved for future use (SPI mode)
3	SCK	
4	RX/IN	UART RX
5	TX/OUT	UART TX
6	GND	Power supply ground.

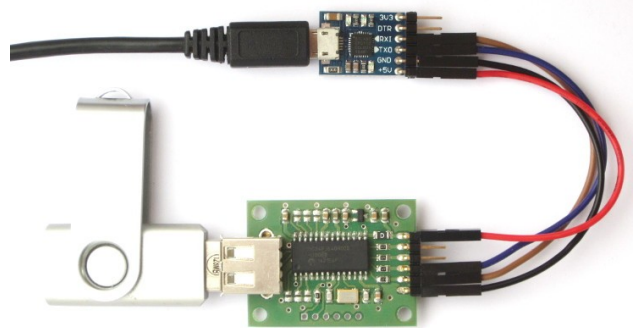

Connector K3 is the programming interface which is compatible with PicKit3. The evaluation board is already flashed with USBula firmware. The programming interface is only needed if customized firmware should be flashed to the microcontroller.

PicKit3 Header K3	
1	VPP/MCLR
2	VDD
3	VSS
4	PGD
5	PGC
6	LVP (not used)

Baudrate

The baudrate of the serial interface can be set through jumpers J4, J5 and J6. The board is shipped with open jumpers (auto baudrate).

J6	J5	J4	Baudrate (Baud)
X	X	X	1200
X	X		2400
X		X	9600
X			19200
	X	X	38400
	X		57600
		X	115200
			Auto-Baudrate (default)

Serial protocol

The serial protocol is documented in the USBula User Manual:
https://www.fischl.de/usbula/download/USBula_UserManual.pdf

Schematics diagram

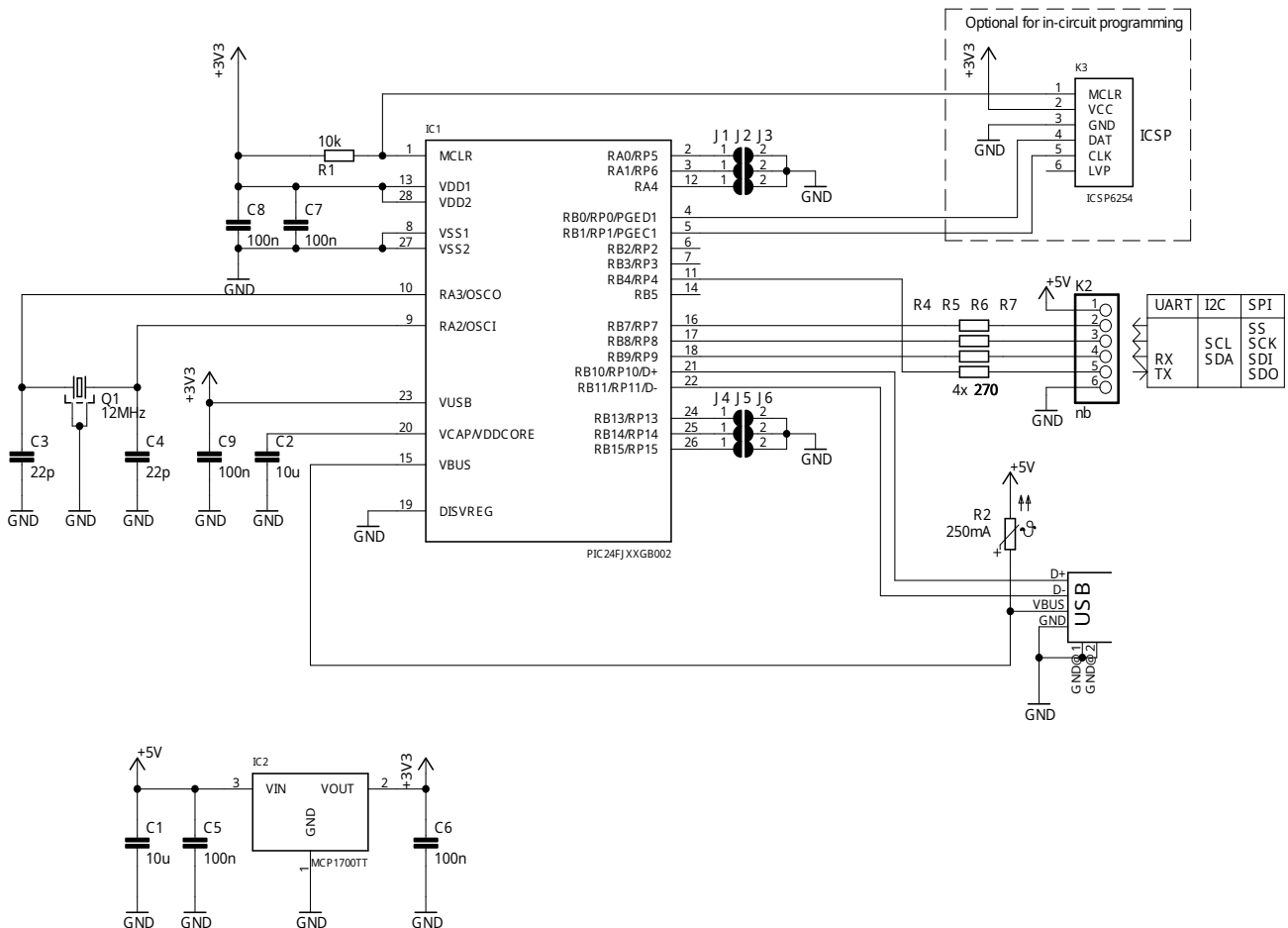

Evaluation board notice

USBula EB is an evaluation board intended for use for engineering development or evaluation purposes in laboratory environment only. It is not considered as an end user application. If you intend to use it in an end-product, you have to ensure in your own responsibility that the device meets the relevant regulations (e.g. CE, FCC).